

Yacht Pro

Products for professional use





Content

Primers & Fillers	5
Below the waterline	6
Above the waterline	10
Above and below the waterline	14
Antifoulings	17
Self-polishing	18
Hard	24
Thin-Film Biocide-Free	26
Fouling Control Systems	29
Fouling Defence	34
Fouling Release	35
Fouling Defence and Release	39
Topcoats	43
Speciality products	49
Interior Coatings	50
Other	55
Thinners & Cleaners	59
Health & Safety	63

Primers & Fillers

- Below the waterline
- Above the waterline
- Above and below the waterline



Underwater Primer 26031

One-component underwater primer

Materials
Glass fibre / Wood / Steel



Description

Fast-drying underwater primer containing aluminium flakes. For use as a sealer onto old antifouling or as a tiecoat over an epoxy primed surface before antifouling.

Recommended use

Suitable on glass fibre, wood and steel. For use on all areas below the waterline including keels.

Product overview

Finish	Flat
Volume Solids (% - ±2)	39
Theoretical Spreading Rate	7.8 m ² /L - 125 µm WFT
Min. Overcoating Time (self)	10°C - 4.5 h 20°C - 2.5 h 30°C - 2 h
Min. Overcoating Time (AF)	10°C - 4.5 h 20°C - 2.5 h 30°C - 2 h
Mixed VOC (g/L)	476

Shades & Can sizes



Aluminium Grey
2.5 | 5 | 20L

Application details

Mixing ratio	N/A
Thinner	08111
Cleaning of tools	Thinner 08111
Pot life (Airless spray)	N/A
Film thickness (micron)	50 (dft) / 125 (wft)

- Excellent adhesion
- Can be used to seal unknown antifouling
- Seals leaching of copper from old antifouling

Gel Primer 45580

Two-component primer for gelcoats

Material
Glass fibre



Description

High build epoxy primer for use as a bond between glass fibre reinforced polyester and antifouling. Also for prevention of osmotic blistering in glass fibre reinforced polyester.

Recommended use

Suitable on glass fibre hulls below the waterline. Especially designed for professional applications where short recoating intervals are needed.

Product overview

Finish	Flat
Volume Solids (% - ±2)	45
Theoretical Spreading Rate	4.5 m ² /L - 225 µm WFT
Min. Overcoating Time (self)	10°C - 6 h 20°C - 3 h 30°C - 2.5 h
Min. Overcoating Time (AF)	10°C - When tacky 20°C - When tacky (30-60min) 30°C - When tacky
Mixed VOC (g/L)	475

Shades & Can sizes

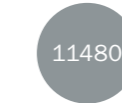

Stone Grey 5 | 20L
Mid Grey 5 | 20L

Application details

Mixing ratio	Base 45589 + Curing agent 98580 4 : 1 by volume
Thinner	08450
Cleaning of tools	Tool Cleaner 99610 Thinner 08450
Pot life (Airless spray)	10°C - 4 h 20°C - 2 h 30°C - 30 min
Film thickness (micron)	100 (dft) / 200 (wft)

- Excellent adhesion to gelcoat
- Fast curing
- Antifouling can be directly applied

Pro Tiecoat 49200

Anticorrosive two-component antifouling tiecoat

Materials
Steel / Aluminium / GRP



Description

High performance anticorrosive epoxy tiecoat for below the waterline.

Recommended use

For immersion service used as a tiecoat between epoxy and one-component coatings.

It can also replace one anticorrosive primer coat for the underwater coating system and at the same time act as tiecoat for antifouling or it may also be used as a sealer over old antifoulings.

- Excellent adhesion to epoxy primers
- Perfect substrate for antifoulings
 - Seals in old antifoulings

Product overview

Finish	Flat
Volume Solids (% - ±2)	57
Theoretical Spreading Rate	5.7 m ² /L – 175 µm WFT
Min. Overcoating Time (self)	N/A
Min. Overcoating Time (AF)	10°C - 10 h 20°C - 5 h 30°C - 4 h
Mixed VOC (g/L)	391

Shades & Can sizes

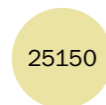

Yellowish Grey
2.5 | 5 | 20L

Application details

Mixing ratio	Base 49209 + Curing agent 98191 7 : 1 by volume
Thinner	08450
Cleaning of tools	Tool Cleaner 99610 Thinner 08450
Pot life (Airless spray)	10°C - 2.5 h 20°C - 2.5 h 30°C - 1 h
Film thickness (micron)	100 (dft) / 175 (wft)

Hempadur 15570

Two-component epoxy hold primer

Material
Steel



Description

Suitable for use as a holding primer below the waterline with extended overcoating intervals. Available in various shades including reddish grey (12430) shade that contains Micaceous Iron Oxide.

Recommended use

As a holding (blast) primer in new building or maintenance scenarios where long overcoating intervals with other epoxy systems may be required. MIO shade is particularly suited for application in humid conditions or on damp steel.

- Extended maximum overcoating interval
- Can be applied to moist steel
- Excellent substrate for epoxy systems

Product overview

Finish	Flat
Volume Solids (% - ±2)	54
Theoretical Spreading Rate	5.4 m ² /L – 200 µm WFT
Min. Overcoating Time (self - above the waterline)	10°C - 8 h 20°C - 4 h 30°C - 3 h
Min. Overcoating Time (self - below the waterline)	10°C - 16 h 20°C - 8 h 30°C - 6 h
Mixed VOC (g/L)	415

Shades & Can sizes

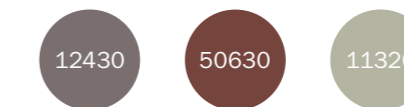

Reddish Grey 20L Red 20L Grey 20L

Application details

Mixing ratio	Base 15579 + Curing agent 95570 3 : 1 by volume
Thinner	08450
Cleaning of tools	Tool Cleaner 99610 Thinner 08450
Pot life (Airless spray)	10°C - 2 h 20°C - 2 h 30°C - 1 h
Film thickness (micron)	100 (dft) / 200 (wft)

Uni-Primer 13140

One-component direct-to-metal primer

Material
Steel



Description

Fast-drying primer with rust-inhibiting pigments that can be applied direct to roughened steel.

Recommended use

Above the waterline as a versatile primer on steel and other metal surfaces in a mild to medium corrosive environment. Ideal undercoat for Hempalin and Hempatex topcoats.

Product overview

Finish	Flat
Volume Solids (% - ±2)	42
Theoretical Spreading Rate	8.4 m ² /L – 125 µm WFT
Min. Overcoating Time (self)	10°C - 12 h 20°C - 6 h 30°C - 4.5 h
Min. Overcoating Time (Topcoat)	10°C - 4 h 20°C - 2 h 30°C - 1.5 h
Mixed VOC (g/L)	518

Shades & Can sizes

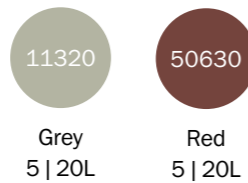

Application details

Mixing ratio	N/A
Thinner	08080
Cleaning of tools	Thinner 08080
Pot life (Airless spray)	N/A
Film thickness (micron)	50 (dft) / 125 (wft)

- Suitable above the waterline
- Reduces need for multiple maintenance primers
- Contains rust-inhibiting pigments

Hempadur 15553

Two-component epoxy stainless steel primer

Materials
Stainless Steel / Aluminium



Description

Flexible impact-resistant primer for stainless steel and aluminium.

Recommended use

As a primer where surface roughening is not achievable. For use only above the water on stainless steel and aluminium parts.

Product overview

Finish	Flat
Volume Solids (% - ±2)	55
Theoretical Spreading Rate	11 m ² /L – 100 µm WFT
Min. Overcoating Time (self)	10°C - 12 h 20°C - 6 h 30°C - 4.5 h
Min. Overcoating Time (Topcoat)	10°C - 12 h 20°C - 6 h 30°C - 4.5 h
Mixed VOC (g/L)	388

Shades & Can sizes

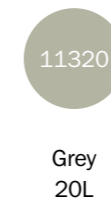

Application details

Mixing ratio	Base 15557 + Curing agent 98021 3 : 1 by volume
Thinner	08450
Cleaning of tools	Tool Cleaner 99610 Thinner 08450
Pot life (Airless spray)	10°C - 2 h 20°C - 2 h 30°C - 1 h
Film thickness (micron)	50 (dft) / 100 (wft)

- Suitable for stainless steel & anodized aluminium
- Surface roughening not required
- Flexible & impact-resistant

Hempadur Mastic 45880

Two-component epoxy build primer

Materials
Steel / Aluminium



Description

High solids, high build primer for use under the polyurethane topcoats.

Recommended use

Above water as a low VOC, high film build primer with extended re-coating times for heavy duty polyurethane topcoats.

Product overview

Finish	Semi-Gloss
Volume Solids (% - ±2)	80
Theoretical Spreading Rate	6.4 m ² /L – 150 µm WFT
Min. Overcoating Time (self)	10°C - 30 h 20°C - 10 h 30°C - 7.5 h
Min. Overcoating Time (Topcoat)	10°C - 30 h 20°C - 10 h 30°C - 7.5 h
Mixed VOC (g/L)	216

Shades & Can sizes

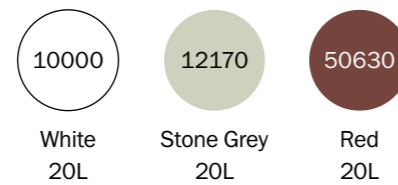

Application details

Mixing ratio	Base 45889 + Curing Agent 95880 3 : 1 by volume
Thinner	08450
Cleaning of tools	Tool Cleaner 99610 Thinner 08450
Pot life (Airless spray)	10°C - 2 h 20°C - 1 h 30°C - 30 min
Film thickness (micron)	125 (dft) / 150 (wft)

- Suitable above the waterline
- Primer for heavy duty topcoats
- Low VOC

Profiler 35370

Two-component epoxy fairing filler

Materials
Steel / Glass fibre



Description

Lightweight smooth epoxy filler with strong adhesion and water resistance. Easy to sand when fully cured.

Recommended use

As a filler and fairing compound above the waterline. Especially suitable for profiling large areas and detailed fairing where structural strength is important. It can be used on most primed rigid substrates and can be applied up to 10-12mm for a uniform smooth film build.

Product overview

Finish	Semi-Gloss
Volume Solids (% - ±2)	100
Theoretical Spreading Rate	N/A
Min. Overcoating Time @ 1mm (self)	10°C - 48 h 20°C - 24 h 30°C - 12 h
Min. Overcoating Time @ 1mm (Epoxy)	10°C - 48 h 20°C - 24 h 30°C - 12 h
Mixed VOC (g/L)	2
Density (Kg/L)	0.7

Shades & Can sizes

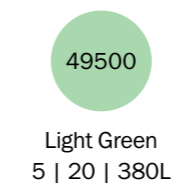

Light Green
5 | 20 | 380L

Application details

Mixing ratio	Base 35379 + Curing agent 95720 1 : 1 by volume
Thinner	Do not dilute
Cleaning of tools	Tool Cleaner 99610
Pot life (Airless spray)	10°C - 1.5 h 20°C - 45 min 30°C - 30 min
Film thickness (micron)	Up to 25mm

- Low density / lightweight
- Smooth
- Easy to sand with minimal shrinkage

Premium Primer 17880

Materials
Steel / Aluminium / GRP / Stainless Steel



Two-component universal epoxy primer

Description

Highly versatile universal primer for use above and below the waterline. Excellent barrier coating and resistant to abrasion.

Recommended use

Is intended as a direct-to-substrate primer for keel-to-rail use on all size yachts made of GRP, FRP, steel, or aluminium. The product is suitable to be overcoated with tiecoats, fillers or other coatings as specified.

Product overview

Finish	Semi-Flat
Volume Solids (% - ±2)	72
Theoretical Spreading Rate	5.76 m ² /L – 160 µm WFT
Min. Overcoating Time (self)	10°C - 6 h 20°C - 3 h 30°C - 2.5 h
Min. Overcoating Time (other)	10°C - 6 h 20°C - 3 h 30°C - 2.5 h
Mixed VOC (g/L)	196

Shades & Can sizes

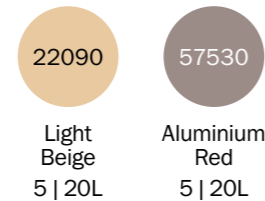

Light Beige 5 | 20L
Aluminium Red 5 | 20L

Application details

Mixing ratio	Base 17889 + Curing agent 95870 4 : 1 by volume
Thinner	08450
Cleaning of tools	Tool Cleaner 99610
Pot life (Airless spray, Brush)	10°C - 2 h 20°C - 1 h 30°C - 30 min
Film thickness (micron)	125 (dft) / 160 (wft)

- Excellent anticorrosive
- Very good mechanical properties
- Short drying time
- Curing down to -10°C
- Keel-to-rail primer

Light Primer 45550

Materials
Steel / Aluminium / GRP / Wood / Stainless Steel / Plywood



Two-component multi-purpose epoxy primer

Description

High performance epoxy primer and undercoat for use both above and below the waterline. Superb corrosion, impact and water resistance.

Recommended use

As a primer below and above the waterline on boats made of aluminium, glass fibre reinforced polyester, wood, plywood and steel. Also for prevention and repair of osmotic blistering in the glass fibre reinforced polyester, and for protection of keels and rudders.

Product overview

Finish	Flat
Volume Solids (% - ±2)	52
Theoretical Spreading Rate	4.9 m ² /L – 200 µm WFT
Min. Overcoating Time (self)	10°C - 16 h 20°C - 8 h 30°C - 6 h
Min. Overcoating Time (Tiecoat)	10°C - 4 h 20°C - 2 h 30°C - 1 h
Mixed VOC (g/L)	433

Shades & Can sizes

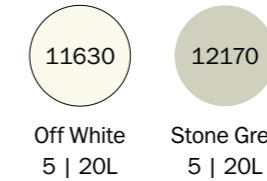

Off White 5 | 20L
Stone Grey 5 | 20L

Application details

Mixing ratio	Base 45559 + Curing agent 95360 2 : 1 by volume
Thinner	08450
Cleaning of tools	Tool Cleaner 99610 Thinner 08450
Pot life (Airless spray)	10°C - 2 h 20°C - 2 h 30°C - 30 min
Film thickness (micron)	100 (dft) / 200 (wft)

- Excellent adhesion to all yacht substrates
- Excellent water barrier
- Can be applied at low temperatures

Antifouling

- Self-polishing
- Hard
- Thin-film biocide-free

Mille NCT 71880

Self-polishing antifouling

Materials
Glass fibre / Wood / Plywood / Steel



Description

High performance, self-polishing antifouling. Hempel's patented binder technology ensures outstanding fouling protection and colour retention all season. Hempel's Mille NCT 71880 is compatible with virtually all other antifouling systems.

Recommended use

Suitable for boats made of glass fibre, wood, plywood and steel. Do not use on aluminium or other light-alloy metals. Risk of corrosion in case of direct contact.

Product overview

Finish	Flat
Volume Solids (% - ±2)	50
Theoretical Spreading Rate	10 m ² /L – 100 µm WFT
Min. Overcoating Time (self)	10°C - 8 h 20°C - 4 h 30°C - 2 h
Min. Time To Immersion	10°C - 36 h 20°C - 24 h 30°C - 24 h
Mixed VOC (g/L)	423

Shades & Can sizes



Application details

Mixing ratio	N/A
Thinner	08080
Cleaning of tools	Tool Cleaner 99610 Thinner 08080
Pot life (Airless spray)	N/A
Film thickness (micron)	50 (dft) / 100 (wft)

- Superior mechanical strength
- Premium crack resistance
- Excellent colour retention all season long

Mille NCT 7188W

Self-polishing antifouling

Materials
Glass fibre / Wood / Plywood / Aluminium / Steel



Description

High performance, self-polishing antifouling. Hempel's patented binder technology ensures outstanding fouling protection and colour retention all season.

Recommended use

As an antifouling for boats of glass fibre, wood, plywood, steel and aluminium.

Product overview

Finish	Flat
Volume Solids (% - ±2)	53
Theoretical Spreading Rate	10.6 m ² /L – 100 µm WFT
Min. Overcoating Time (self)	10°C - 8 h 20°C - 4 h 30°C - 2 h
Min. Time To Immersion	10°C - 36 h 20°C - 24 h 30°C - 24 h
Mixed VOC (g/L)	406

Shades & Can sizes



Application details

Mixing ratio	N/A
Thinner	08080
Cleaning of tools	Tool Cleaner 99610 Thinner 08080
Pot life (Airless spray)	N/A
Film thickness (micron)	50 (dft) / 100 (wft)

- Superior mechanical strength
- Premium crack resistance
- Clean, white colour
- Can be applied on aluminium with suitable priming

Classic 71220

Self-polishing antifouling

Materials

Glass fibre / Wood / Plywood / Steel



Description

Efficient polishing (erodible) antifouling providing good protection all season.

Recommended use

As an antifouling for boats of glass fibre, wood, plywood and steel. Do not use on aluminium or other light-alloy metals. Risk of corrosion in case of direct contact.

Product overview

Finish	Flat
Volume Solids (% - ±2)	50
Theoretical Spreading Rate	10 m ² /L – 100 µm WFT
Min. Overcoating Time (self)	10°C - 8 h 20°C - 4 h 30°C - 2 h
Min. Time To Immersion	10°C - 36 h 20°C - 24 h 30°C - 24 h
Mixed VOC (g/L)	424

Shades & Can sizes

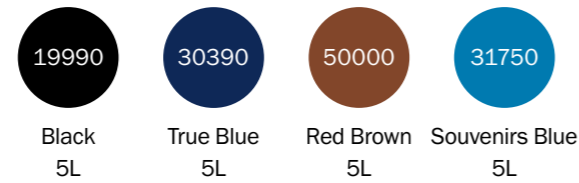

Application details

Mixing ratio	N/A
Thinner	08080
Cleaning of tools	Tool Cleaner 99610 Thinner 08080
Pot life (Airless spray)	N/A
Film thickness (micron)	50 (dft) / 100 (wft)

- Good mechanical strength
- Improved crack resistance
- Good colour retention all season long
 - For cruising speeds

Alu Prop NCT Pro 74830

Self-polishing antifouling

Materials

Glass fibre / Wood / Plywood / Aluminium / Steel



Description

High performance, self-polishing antifouling. Hempel's patented binder technology ensures outstanding fouling protection and colour retention all season.

Recommended use

As an antifouling for boats of glass fibre, wood, plywood, steel and aluminium. For all below waterline areas including stern gear & propellers.

Product overview

Finish	Flat
Volume Solids (% - ±2)	53
Theoretical Spreading Rate	10.6 m ² /L – 100 µm WFT
Min. Overcoating Time (self)	10°C - 8 h 20°C - 4 h 30°C - 2 h
Min. Time To Immersion	10°C - 36 h 20°C - 24 h 30°C - 24 h
Mixed VOC (g/L)	406

Shades & Can sizes

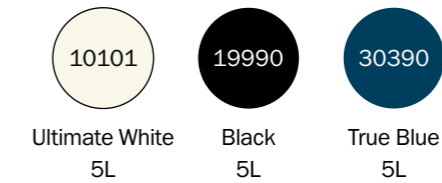

Application details

Mixing ratio	N/A
Thinner	08080
Cleaning of tools	Tool Cleaner 99610 Thinner 08080
Pot life (Airless spray)	N/A
Film thickness (micron)	50 (dft) / 100 (wft)

- Especially suited for aluminium boats
- Bright, clean colours
- Excellent mechanical strength
 - Superior crack resistance

Tiger Xtra 71000

Self-polishing antifouling

Materials
Glass fibre / Wood / Plywood / Steel



Description

High performance, conventional, erodible antifouling providing excellent protection all season.

Recommended use

As an antifouling for glass fibre, wood, plywood and steel. Do not use on aluminium or other light alloy metals. Risk of corrosion in case of contact. For power and sailing boats.

Product overview

Finish	Flat
Volume Solids (% - ±2)	51
Theoretical Spreading Rate	10.2 m ² /L - 100 µm WFT
Min. Overcoating Time (self)	10°C - 8 h 20°C - 4 h 30°C - 2 h
Min. Time To Immersion	10°C - 36 h 20°C - 24 h 30°C - 24 h
Mixed VOC (g/L)	422

Shades & Can sizes

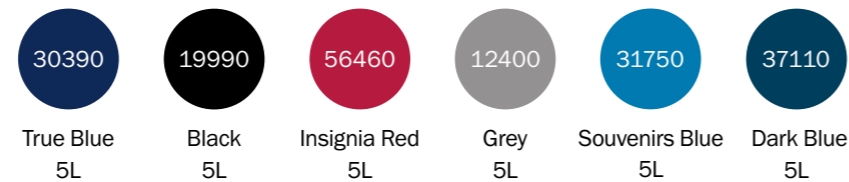

Application details

Mixing ratio	N/A
Thinner	08080
Cleaning of tools	Tool Cleaner 99610 Thinner 08080
Pot life (Airless spray)	N/A
Film thickness (micron)	50 (dft) / 100 (wft)

- High mechanical strength
- Excellent crack resistance
- Suitable for dry-stack or continuous immersion
- Great colour retention
- Just 1 coat can last the season

Tiger Xtra White 7103A

Self-polishing antifouling

Materials
Glass fibre / Wood / Plywood / Steel / Aluminium



Description

High performance, self-polishing antifouling providing excellent protection all season.

Recommended use

As an antifouling for glass fibre, wood, plywood, steel and aluminium. For power and sailing boats.

Product overview

Finish	Flat
Volume Solids (% - ±2)	35
Theoretical Spreading Rate	7 m ² /L - 100 µm WFT
Min. Overcoating Time (self)	10°C - 8 h 20°C - 4 h 30°C - 2 h
Min. Time To Immersion	10°C - 36 h 20°C - 24 h 30°C - 24 h
Mixed VOC (g/L)	405

Shades & Can sizes



Application details

Mixing ratio	N/A
Thinner	08080
Cleaning of tools	Tool Cleaner 99610 Thinner 08080
Pot life (Airless spray)	N/A
Film thickness (micron)	50 (dft) / 100 (wft)

- High mechanical strength
- Excellent crack resistance
- Suitable for dry-stack or continuous immersion
- Great colour retention
- Just 1 coat can last the season

Hard Racing TecCel 76880

Materials
Glass fibre / Wood / Plywood / Steel



Hard matrix antifouling

Description

High performance, hard antifouling providing outstanding protection all season. Includes TecCel technology which ensures reduced friction and increased speed. It changes to its final colour after approximately 1 week of immersion in water.

Recommended use

As an antifouling for boats of glass fibre, wood, plywood and steel. Do not use on aluminium or other light-alloy metals. Risk of corrosion in case of direct contact. For powerboats and regatta yachts.

Product overview

Finish	Flat
Volume Solids (% - ±2)	49
Theoretical Spreading Rate	9.8 m ² /L - 100 µm WFT
Min. Overcoating Time (self)	10°C - 8 h 20°C - 4 h 30°C - 2 h
Min. Time To Immersion	10°C - 36 h 20°C - 24 h 30°C - 24 h
Mixed VOC (g/L)	437

Shades & Can sizes



Application details

Mixing ratio	N/A
Thinner	08080
Cleaning of tools	Tool Cleaner 99610 Thinner 08080
Pot life (Airless spray)	N/A
Film thickness (micron)	50 (dft) / 100 (wft)

- Super smooth racing finish
- Reduced friction & increased speed
- Excellent crack resistance
- Superior colour retention all season long

Hard Racing TecCel 7688W

Materials
Glass fibre / Wood / Plywood / Aluminium / Steel



Hard matrix antifouling

Description

High performance, hard antifouling providing outstanding protection all season. Includes TecCel technology which ensures reduced friction and increased speed.

Recommended use

As an antifouling for boats of glass fibre, wood, plywood, steel and aluminium. For powerboats and regatta yachts.

Product overview

Finish	Flat
Volume Solids (% - ±2)	53
Theoretical Spreading Rate	10.8 m ² /L - 100 µm WFT
Min. Overcoating Time (self)	10°C - 8 h 20°C - 4 h 30°C - 2 h
Min. Time To Immersion	10°C - 36 h 20°C - 24 h 30°C - 24 h
Mixed VOC (g/L)	409

Shades & Can sizes

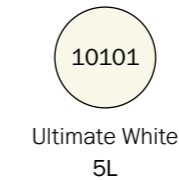

Application details

Mixing ratio	N/A
Thinner	08080
Cleaning of tools	Tool Cleaner 99610 Thinner 08080
Pot life (Airless spray)	N/A
Film thickness (micron)	50 (dft) / 100 (wft)

- Super smooth racing finish
- Reduced friction & increased speed
- Excellent crack resistance
- Superior colour retention all season long

Hempaspeed TF 77222

Hard thin-film, biocide-free antifouling

Materials

Steel / Aluminium / GRP / Stainless Steel



Description

A high performance, hard biocide-free, thin-film coating. Forms an ultra-smooth surface that minimizes growth and reduces drag.

Recommended use

Hempaspeed TF is for use as an antifouling for boats of glass fibre, steel and aluminium. Suitable for pleasure boats and racing / regatta boats. Ideal for both fresh and salt water use.

Product overview

Finish	Glossy
Volume Solids (% - ±2)	43
Theoretical Spreading Rate	11 m ² /L - 90 µm WFT
Min. Overcoating Time (self)	10°C - 8 h 20°C - 4 h 30°C - 3 h
Min. Time To Immersion	10°C - 24 h 20°C - 24 h 30°C - 24 h
Mixed VOC (g/L)	507

Shades & Can sizes

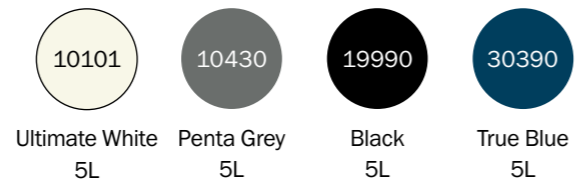

Application details

Thinner	Do not dilute
Cleaning of tools	Thinner 08080
Film thickness (micron)	40 (dft) / 90 (wft)

- Biocide-free
- Easy to clean
- Ultra smooth

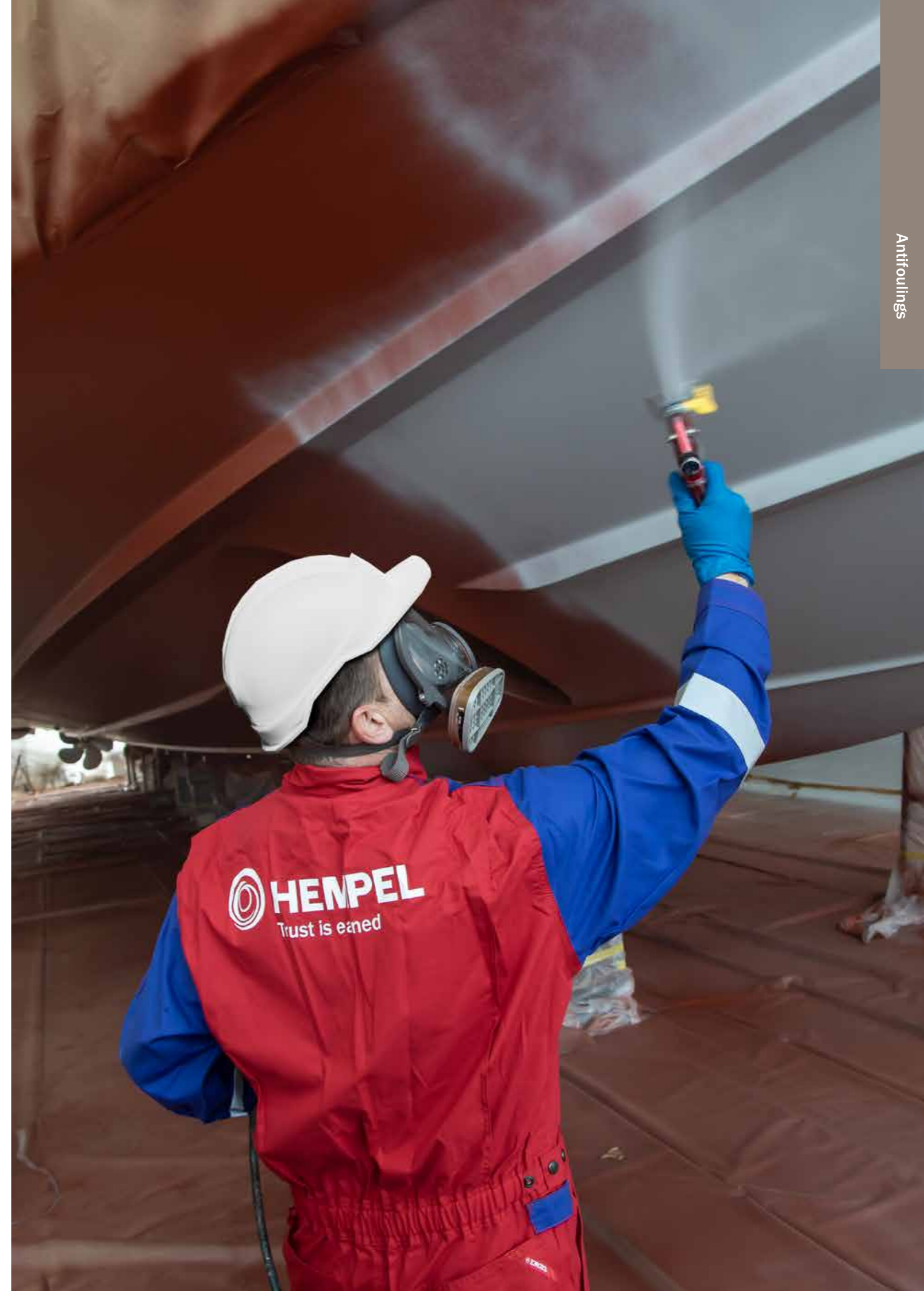

Fouling Control Systems

- Fouling Defence
- Fouling Release
- Fouling Defence and Release

Combining the knowledge on different technologies, Hempel has created **Fouling defence** and **Fouling release** solutions for you to choose from:

Fouling defence

Our unique Actiguard technology gives you the best of two worlds: silicone-hydrogel and diffusion control of biocides, all in a single fouling defence coat. You can expect 6 percent fuel savings compared to best-in-class antifoulings over the entire service interval, regardless of trading patterns and sailing speed, and a clean hull over an idle period of up to 120 days. The result is exceptional fouling control performance and lower CO₂ emissions over docking intervals of up to 60 months.

Fouling release

Our fouling release technology is based on biocide-free silicone and new advanced hydrogel technology, giving you a smooth hull surface that makes it difficult for fouling organisms to attach. The result is less drag, average 6 percent fuel savings straight out of dock and lower CO₂ emissions, increasing the efficiency of your fleet and offering superb return on investment. You can use our fouling release technology on any type of yacht, even those currently using another type of fouling control coating.



Fouling control systems overview

	Fouling defence	Fouling release
	Hempaguard X7	Hempasil Pro
Biocide-free	✗	✓
Instant effect on water contact	✓	✓
High activity level	✓	✓
Low activity level	✓	✗
Up to 120 days idle time	✓	✗
Possible to switch from tropical to colder waters	✓	✓
Easy overcoating	✓	✓
Application in warm environment	✓	✓
Full return on paint investment	✓	✗
No fouling cleaning needed	✓	✗
Products suitable for touch ups, repairs and supporting small vessels	 Silic Pro*	 Silic One
Suitable for propellers	✓	✓

* Only available in certain countries

Fouling Defence & Release systems

Hempaguard® X7

Full system for new and bare hull – 5 year scheme

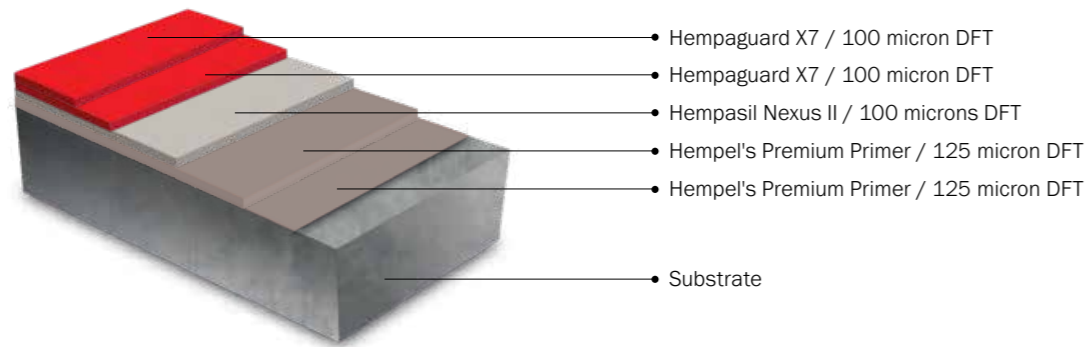

Converting from the existing antifouling system – 3 year scheme

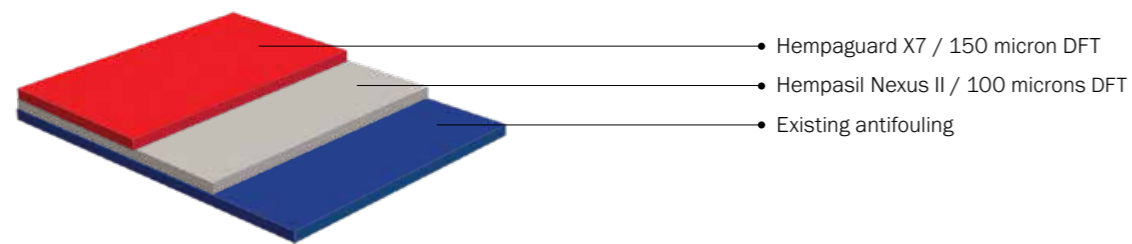

Hempasil Pro

Full system for new and bare hull – 3 year scheme

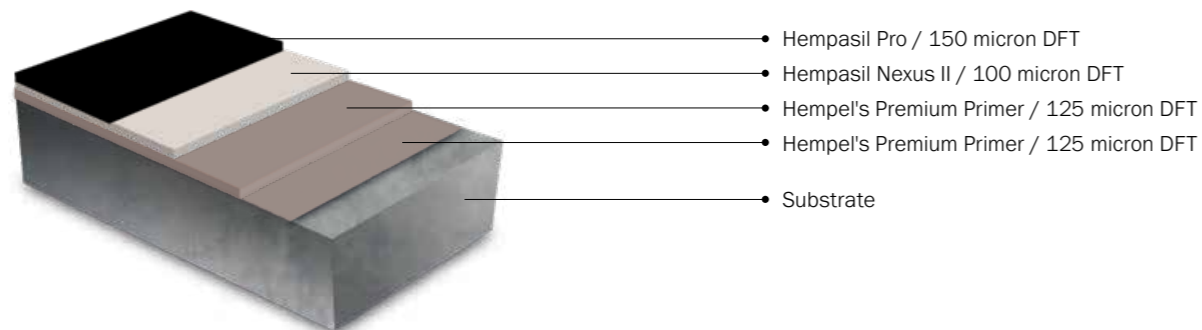

Converting from the existing antifouling system – 3 year scheme

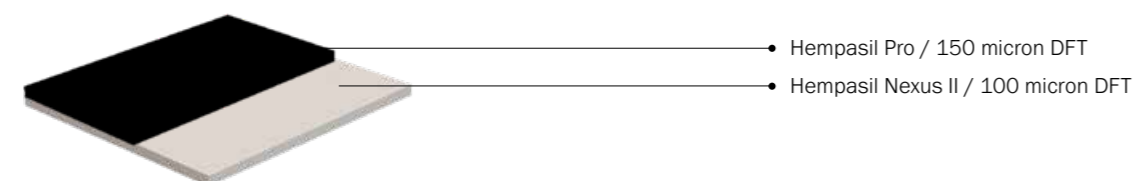

Hempel's Silic One

New boat without epoxy

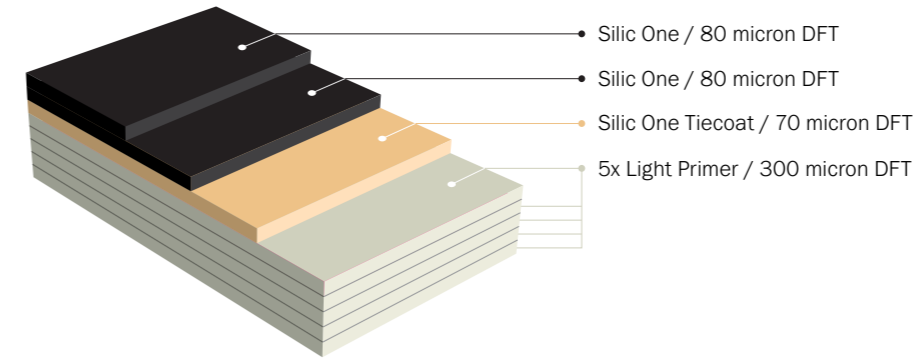

New boat or bare boat with epoxy

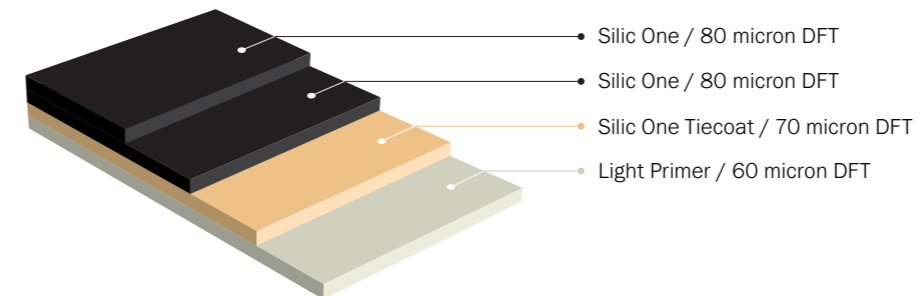

Application on top of old antifouling in good condition

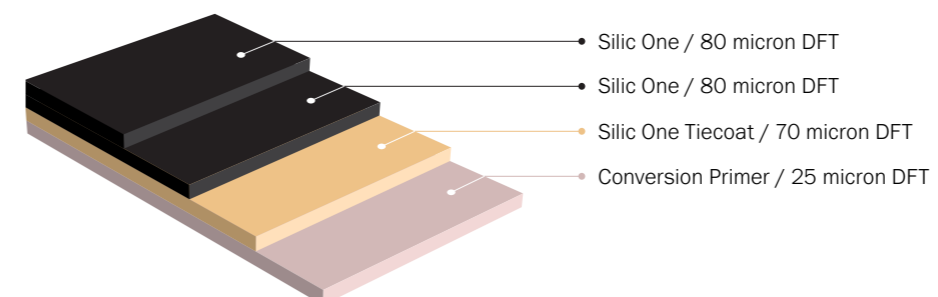

Hempaguard X7 89900

Materials
Steel / Aluminium / GRP /
Stainless Steel



Two-component fouling defence coating

Description

Advanced fouling defence coating, with high solids content, based on ActiGuard® technology. ActiGuard® combines the effect of advanced hydrogel silicone and an efficient fouling preventing biocides to boost the antifouling barrier and prolong the fouling-free period. Possesses a high fuel saving potential and is also suitable for vessels operating with long service intervals (up to 60 months) and/or very long idle periods (up to 120 days).

Recommended use

As a fouling defence finish on all boat types, with no limitation on service speeds, including slow/ultraslow yachts. The product is also suitable for propellers.

Product overview

Finish	Glossy
Volume Solids (% - ±2)	70
Theoretical Spreading Rate	7.0 m ² /L - 140 µm WFT
Min. Overcoating Time (self)	10°C - 21 h 20°C - 8 h 30°C - 6 h
Min. Time To Immersion	10°C - 24 h 20°C - 24 h 30°C - 24 h
Mixed VOC (g/L)	260

Shades & Can sizes

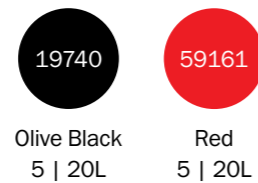

Olive Black 5 | 20L Red 5 | 20L

Application details

Mixing ratio	Base 89909 + Crosslinker 98980 17.8 : 2.2 by volume
Thinner	Do not dilute
Cleaning of tools	Thinner 08080
Pot life (Airless Spray)	10°C - 1 h 20°C - 1 h 30°C - 30 min
Film thickness	100 (dft) / 140 (wft)

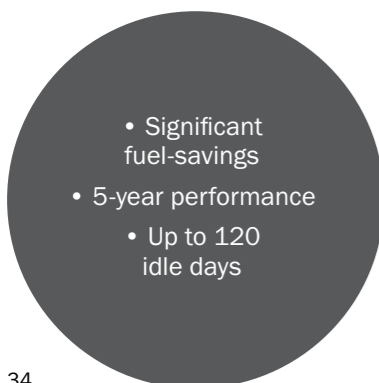

Hempasil Pro 87850

Materials
Steel / Aluminium / GRP /
Stainless Steel



Two-component fouling release coating

Description

4th generation biocide-free, high solids finish, based on advanced hydrogel technology. Provides a smooth, low energy repellent surface with unique fouling release and self-cleaning properties and allows high fuel saving potential compared to traditional antifouling and upto to 6 percent fuel savings immediately out of dock.

Recommended use

As a fouling release finish on all boat types with service speeds above 8 knots. The product can also be used for propellers.

Product overview

Finish	Glossy
Volume Solids (% - ±2)	71
Theoretical Spreading Rate	4.8 m ² /L - 210 µm WFT
Min. Overcoating Time (self)	10°C - 21 h 20°C - 8 h 30°C - 6 h
Min. Time To Immersion	10°C - 24 h 20°C - 24 h 30°C - 24 h
Mixed VOC (g/L)	248

Shades & Can sizes

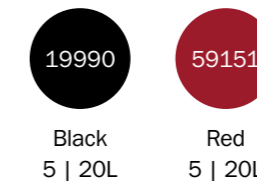

Black 5 | 20L Red 5 | 20L

Application details

Mixing ratio	Base 87859 + Crosslinker 98952 18.4 : 1.6 by volume
Thinner	Do not dilute
Cleaning of tools	Thinner 08080
Pot life (Airless Spray)	10°C - 1 h 20°C - 1 h 30°C - 30 min
Film thickness	150 (dft) / 210 (wft)



Silic One 77450

One-component fouling release coating

Materials
Steel / Aluminium / GRP /
Wood / Stainless Steel



Description

Biocide-free, high solid, fouling release coating. Based on silicone, a hydrogel micro layer provides a smooth, low friction surface which prevents organisms attaching to the hull and propellers. Service life of Hempel's Silic One on the hull is 2 years.

Recommended use

As a fouling release finish on all boat types. For use below the waterline, on propellers and on running gear.

Product overview

Finish	Glossy
Volume Solids (% - ±2)	80
Theoretical Spreading Rate	10 m ² /L - 100 µm WFT
Min. Overcoating Time (self)	10°C - 16 h 20°C - 16 h 30°C - 8 h
Min. Time To Immersion	10°C - 36 h 20°C - 24 h 30°C - 24 h
Mixed VOC (g/L)	117

Shades & Can sizes

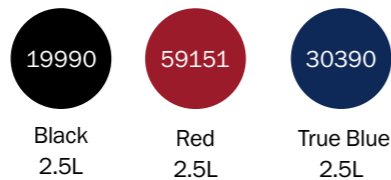

Application details

Mixing ratio	N/A
Thinner	Do not dilute
Cleaning of tools	Thinner 08080
Pot life	1 h after opening the can
Film thickness (micron)	80 (dft) / 100 (wft)

Silic One Tiecoat 27450

One-component tiecoat

Materials
Steel / Aluminium / GRP /
Wood / Stainless Steel



Description

High solid, silicone-based tiecoat for Hempel's Silic One. Secures adhesion between Hempel's Light Primer or Hempel's Conversion Primer and Hempel's Silic One.

Recommended use

For use below the waterline between Hempel's Light Primer 45550 or Hempel's Conversion Primer 45441 and Hempel's Silic One 77450. Also used to touch-up and repair damaged areas.

Product overview

Finish	Semi-Gloss
Volume Solids (% - ±2)	67
Theoretical Spreading Rate	10 m ² /L - 100µm WFT
Min. Overcoating Time (other)	10°C - 16 h 20°C - 8 h 30°C - 4 h
Mixed VOC (g/L)	233

Shades & Can sizes

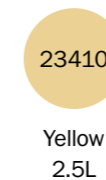

Application details

Mixing ratio	N/A
Thinner	Do not dilute
Cleaning of tools	Thinner 08080
Pot life	1 h after opening the can
Film thickness (micron)	70 (dft) / 100 (wft)

- 2-year fouling protection
- Easy to apply & maintain
 - Biocide-free
 - Fuel saving
- Suitable for propellers

- Great adhesion between primer & finish coats
 - Easy to apply
- Suitable for touch-up & repairs

Conversion Primer 45441

Materials
Steel / Aluminium / GRP /
Stainless Steel



Two-component epoxy primer

Description

Two-component epoxy to enable easy conversion from antifouling to Hempel's Silic One Fouling Release System.

Recommended use

For use as a sealer on antifouling. Secures adhesion between antifouling and Hempel's Silic One Tiecoat 27450. For use on all substrates excluding wood. Can be applied on previously painted antifouling in good condition.

Product overview

Finish	Flat
Volume Solids (% - ±2)	36
Theoretical Spreading Rate	15m ² /L - 70µm WFT
Min. Overcoating Time (self)	10°C - 3 h 20°C - 1.5 h 30°C - 1 h
Min. Overcoating Time (other)	10°C - 4 h 20°C - 2 h 30°C - 1 h
Mixed VOC (g/L)	542

Shades & Can sizes

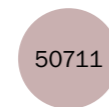

Light red
2.5L

Application details

Mixing ratio	Base 45445 + Curing agent 95441 3 : 1 by volume
Thinner	Do not dilute
Cleaning of tools	Thinner 08450
Pot life	10°C - 8 h 20°C - 8 h 30°C - 4 h
Film thickness (micron)	25 (dft) / 70 (wft)

- Easy conversion to Fouling Release system
- Easy to apply
- Can be applied directly to old antifouling

Hempasil Nexus II 27400

Materials
Steel / Aluminium / GRP /
Stainless Steel



Three-component tiecoat

Description

Three-component silicone-based tiecoat with anticorrosive properties.

Recommended use

For use below the waterline as a tiecoat between epoxy primer and finish coat for the Hempaguard®/Hempasil Systems.

Can also be used to easily convert aged antifouling to Hempaguard or Hempasil systems providing antifouling is in good condition.

Product overview

Finish	Semi-Gloss
Volume Solids (% - ±2)	55
Theoretical Spreading Rate	5.5m ² /L - 190µm WFT
Min. Overcoating Time (self)	N/A
Min. Overcoating Time (X-Tend 27500)	10°C - 5 h 20°C - 4 h 30°C - 3 h
Min. Overcoating Time (Hempasil Pro/X7)	10°C - 12 h 20°C - 6 h 30°C - 4 h
Mixed VOC (g/L)	335

Shades & Can sizes

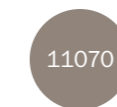

Light Grey
5 l 20L

Application details

Mixing ratio	Base 27409 + Curing agent 98160 + Additive 99710 13.9 : 3.6 : 2.5 by volume
Thinner	Do not dilute
Cleaning of tools	Tool Cleaner 99610 Thinner 08450
Pot life (Airless Spray)	10°C - 1 h 20°C - 1 h 30°C - 30 min
Film thickness (micron)	100 (dft) / 190 (wft)

- Easy conversion to Hempaguard/Hempasil system
- Direct application on top of old antifouling
- Overcoating flexibility*

* Can be combined with Hempel's Nexus X-Tend 27500

Hempasil Nexus X-tend 27500

One-component tiecoat

Materials

Steel / Aluminium / GRP /
Stainless Steel



Description

High solids, silicone-based humidity curing tiecoat for Hempaguard®/Hempasil finishes.

Recommended use

For use below the waterline as a tiecoat, in combination with Nexus II 27400, between epoxy primer and finish coat for the Hempaguard®/Hempasil Systems.

Can also be used as a low temperature tiecoat, in combination with Hempasil Nexus II 27400, for applications below 10°C.

Suitable for touch-up and repair of damaged areas of existing silicone finish coats.

Product overview

Finish	Semi-Gloss
Volume Solids (% - ±2)	65
Theoretical Spreading Rate	5.5m ² /L - 190µm WFT
Min. Overcoating Time (self)	N/A
Min. Overcoating Time (Hempasil Pro/X7)	10°C - 21 h 20°C - 8 h 30°C - 6 h
Mixed VOC (g/L)	249

Shades & Can sizes

23410

Yellow
5 | 20L

Application details

Mixing ratio	N/A
Thinner	Do not dilute
Cleaning of tools	Thinner 08080
Pot life (Airless spray)	10°C - 1 h 20°C - 1 h 30°C - 30 min
Film thickness (micron)	120 (dft) / 190 (wft)

- For applications lower than 10°C
- A 'recovery coat' if rains occurs prior to finish coat application
- Extended overcoating intervals*

* compared to
Hempel's Nexus II 27400



Topcoats



Hempalin Enamel 52140

One-component glossy enamel

Materials
Steel / Wood



Description

Glossy alkyd enamel which forms a flexible weather resistant coating. Resistant to salt water, oils, fuel and other lubricants.

Recommended use

Above the waterline as a general purpose finishing coat in alkyd systems. For use on exterior and interior steel and woodwork in mildly to moderately corrosive environment.

Product overview

Finish	High-Gloss
Volume Solids (% - ±2)	46
Theoretical Spreading Rate	15.3 m ² /L - 75 µm WFT
Min. Overcoating Time (self)	10°C - 16 h 20°C - 8 h 30°C - 6 h
Mixed VOC (g/L)	429

Shades & Can sizes



Application details

Mixing ratio	N/A
Thinner	08080
Cleaning of tools	Thinner 08080
Pot life (Airless spray)	N/A
Film thickness (micron)	30 (dft) / 75 (wft)

- Flexible & resistant
- Interior & exterior
- Ideal for engine rooms

Hempatex Deck Coating Non-Skid 56250

One-component fast-drying acrylic deck paint

Materials
Steel / Glass fibre / Wood



Description

Quick-drying, acrylic, semi-gloss topcoat containing fine granules for an anti-slip finish. Durable with good resistance to weathering and abrasion.

Recommended use

For use on glass fibre, wood and steel. For interior and exterior use above the waterline.

Product overview

Finish	Flat
Volume Solids (% - ±2)	48
Theoretical Spreading Rate	9.2 m ² /L - 100 µm WFT
Min. Overcoating Time (self)	10°C - 7 h 20°C - 4 h 30°C - 3 h
Mixed VOC (g/L)	471

Shades & Can sizes

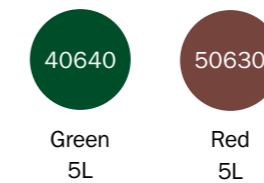

Application details

Mixing ratio	N/A
Thinner	08080
Cleaning of tools	Thinner 08080
Pot life (Airless spray)	N/A
Film thickness (micron)	N/A

- Fast-drying
- Abrasion-resistant
- Skid-proof

Hempathane HS 55610

Two-component gloss topcoat

Materials
Steel / Aluminium / GRP /
Stainless Steel



Description

Glossy polyurethane coating with good gloss and colour retention.

Recommended use

Above the water as a glossy decorative finishing coat in severely corrosive atmospheric environments.

Product overview

Finish	Glossy
Volume Solids (% - ±2)	67
Theoretical Spreading Rate	8.3 m ² /L - 120 µm WFT
Min. Overcoating Time (self)	10°C - 12 h 20°C - 6 h 30°C - 3 h
Mixed VOC (g/L)	342

Shades & Can sizes



Multitint
20L

Application details

Mixing ratio	Base 55619 + Curing agent 97050 7 : 1 by volume
Thinner	08080
Cleaning of tools	Thinner 08080
Pot life (Airless spray)	10°C - 4 h 20°C - 2 h 30°C - 1 h
Film thickness (micron)	80 (dft) / 120 (wft)

- Durable gloss finish
- Good colour retention
- Good gloss retention

Hempathane HS 55810

Two-component high-gloss polyurethane

Materials
Steel / Aluminium / GRP /
Stainless Steel



Description

Two-component polyurethane topcoat with very good gloss and colour retention.

Recommended use

Above the water as a high-gloss decorative finishing coat in severely corrosive atmospheric environments.

Product overview

Finish	High-Gloss
Volume Solids (% - ±2)	64
Theoretical Spreading Rate	16 m ² /L - 60 µm WFT
Min. Overcoating Time (self)	10°C - 24 h 20°C - 16 h 30°C - 8 h
Mixed VOC (g/L)	369

Shades & Can sizes



Multitint
5 | 20L

Application details

Mixing ratio	Base 55819 + Curing agent 95373 4 : 1 by volume
Thinner	08080
Cleaning of tools	Thinner 08080
Pot life (Airless Spray)	10°C - 8 h 20°C - 4 h 30°C - 2 h
Film thickness (micron)	40 (dft) / 60 (wft)

- Durable high-gloss finish
- High volume solids
- Good colour retention

Speciality products

- Interior Coatings
- Other



Yacht Pro Interior Coatings

Features	Interior Primer 17950	Interior Topcoat 57970
High solids	✓	✓
<360g/lit VOC	✓	✓
Very high gloss	✗	✓
Abrasion resistant	✓	✓
Chemically resistant	✓	✓
Easy to apply by all methods	✓	✓
Surface Spread of Flame Compliant	✓	✓
Available in multiple shades	✓	✓
Fast drying	✓	✓
Extended overcoating intervals	✓	✓

Systems

System 1 - Behind insulation

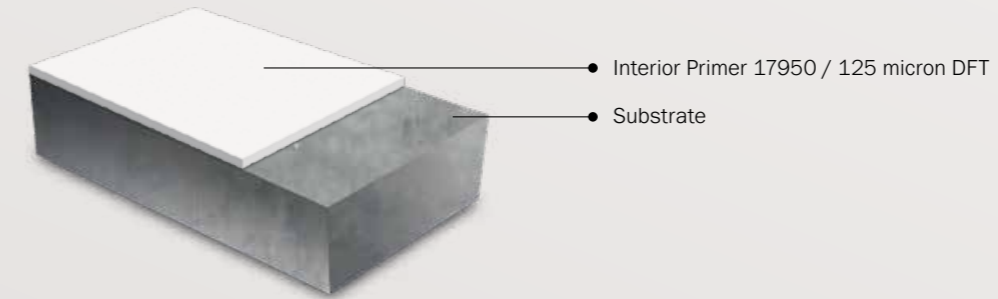

System 2 - Voids (Damp areas)

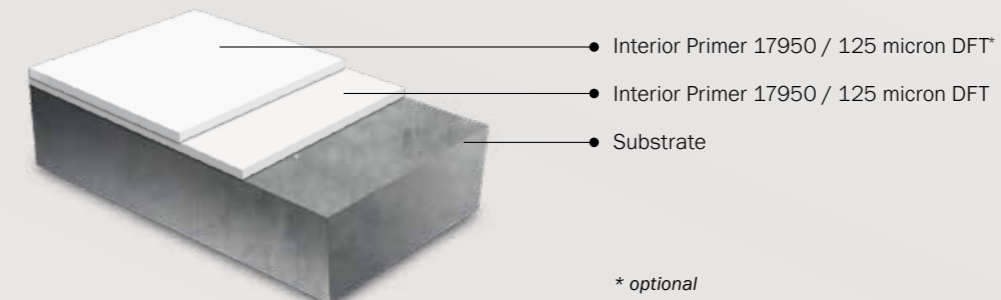

System 3 - Bilges

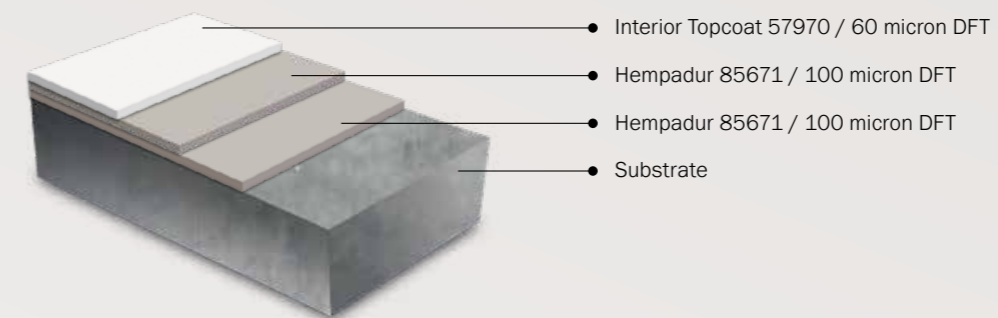

System 4 - Visible Areas

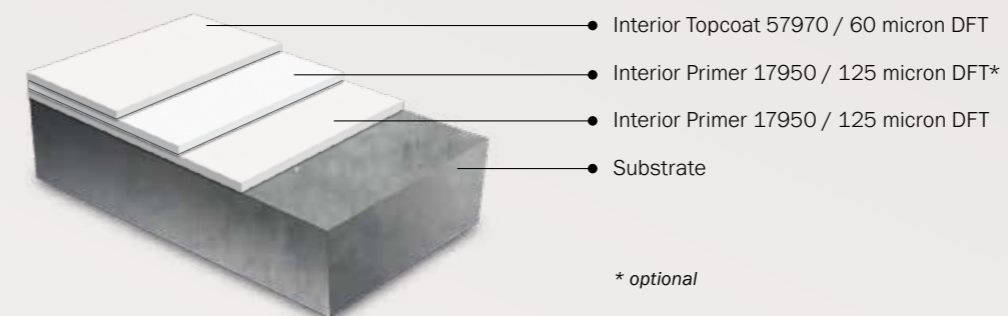

Interior Primer 17950

Two-component primer

Application method (tools)



Product Description

A fast drying, high solids epoxy primer, with great abrasion and excellent long term corrosion resistance. The mechanical properties not only give protection you can trust but also great aesthetics.

Besides that, it offers significant savings in VOC emissions in comparison to other typical dedicated Yacht interior primers. Hempel's Interior Primer, with full Surface Spread Of Flame Certification and long overcoating times, uses less paint than market average interior primers also reducing the impact on the environment.

Product overview

Finish	Semi-Gloss
Volume Solids (% - ±2)	85
Theoretical Spreading Rate	6.8 m ² /L – 150 µm WFT
Min. Overcoating Time (self)	10°C - 7 h 20°C - 3 h 30°C - 1.5 h
Min. Overcoating Time (Topcoat)	10°C - 7 h 20°C - 3 h 30°C - 1.5 h
Mixed VOC (g/L)	196

Shades & Can sizes



White
5 | 20L

Application details

Mixing ratio	Base 17959 + Curing agent 95090 4 : 1 by volume
Thinner	08450
Cleaning of tools	Tool Cleaner 99610
Pot life (Airless spray)	10°C - 2 h 20°C - 1 h 30°C - 30 min
Film thickness (micron)	125 (dft) / 150 (wft)

- Fast drying
- Great abrasion resistance
- Long-term corrosion resistance
- Less VOC emissions

Interior Topcoat 57970

Two-component topcoat

Application method (tools)



Product Description

A high gloss, durable finish especially designed for areas you want to showcase while preserving strong chemical-resistance.

With higher solids allowing one coat application in some instances, and less VOC emissions compared to other interior systems, Hempel's Interior Topcoat 57970 delivers performance and sustainability without compromise. Applied over Interior Primer 17950, this system has full Surface Spread of Flame Certification, saves paint, reduces emissions and gives long-term protection making it suitable for use in all areas of yacht interiors.

Product overview

Finish	High-Gloss
Volume Solids (% - ±2)	63
Theoretical Spreading Rate	11 m ² /L – 90 µm WFT
Min. Overcoating Time (self)	10°C - 24 h 20°C - 12 h 30°C - 6 h
Mixed VOC (g/L)	316

Shades & Can sizes



White
5 | 20L



White
5 | 20L



Multitint
5 | 20L

Application details

Mixing ratio	Base 57979 + Curing agent 97971 10 : 3 by volume
Thinner	08710
Cleaning of tools	Thinner 08710
Pot life (Airless spray)	10°C - 4 h 20°C - 4 h 30°C - 2 h
Film thickness (micron)	60 (dft) / 90 (wft)

- High gloss
- Durable finish
- Reduces emissions
- Long-term protection

Hempadur 35560

Material
Steel



Two-component epoxy tank primer

Description

Solvent-free, epoxy primer for use in fresh water (potable) tanks.

Recommended use

As a lining in potable water tanks and pipelines.

Certificates/Approvals

Approved by WRAS for potable water up to 35°C.

Certified by NSF International to NSF/ANSI standard 61 - Drinking Water System Components - Health Effects.

Product overview

Finish	Glossy
Volume Solids (% - ±2)	100
Theoretical Spreading Rate	5 m ² /L - 200 µm WFT
Min. Overcoating Time (self)	10°C - 40 h 20°C - 16 h 30°C - 8 h
Min. Overcoating Time (other)	N/A
Mixed VOC (g/L)	0

Shades & Can sizes

20324	50904
Cream 19.4L	Light Red 19.4L

Application details

Mixing ratio	Base 35569 + Curing agent 98560 3.4 : 1 by volume
Thinner	Do not dilute
Cleaning of tools	Tool Cleaner 99610 Thinner 08450
Pot life (Airless spray)	10°C - 3 h 20°C - 1.5 h 30°C - 45 min
Film thickness (micron)	200 (dft) / 200 (wft)

- Perfect for potable water tanks
- Solvent-free
- Benzyl alcohol free

» Hempel's interior systems are so easy to work with, definitely an excellent solution I can rely on to enhance and protect the interior surfaces. «

Huub de Koning,
Owner and Managing Director of De Koninggroep

High Protect II 35780

Two-component epoxy osmosis repair coating

Material
Glass fibre



Description

Solvent-free, high-build epoxy for osmosis protection and treatment. Easy to apply with good tolerance to environmental conditions. Forms a hard, tough, water-resistant coating.

Recommended use

For use as a primer for the prevention and repair of osmotic blistering in the glass fibre.

Product overview

Finish	High-Gloss
Volume Solids (% - ±2)	100
Theoretical Spreading Rate	11 m ² /L – 150 µm WFT
Min. Overcoating Time (self)	10°C - 20 h 20°C - 8 h 30°C - 4 h
Min. Overcoating Time (other)	10°C - 20 h 20°C - 8 h 30°C - 4 h
Mixed VOC (g/L)	34

Shades & Can sizes

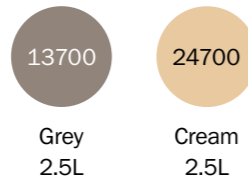

Application details

Mixing ratio	Base 35789 + Curing agent 95078 1.5 : 1 by volume
Thinner	Do not dilute
Cleaning of tools	Thinner 08450
Pot life (Airless spray)	10°C - 2 h 20°C - 2 h 30°C - 1 h
Film thickness (micron)	150 (dft) / 150 (wft)

- Suitable above & below the waterline
- For the repair of osmotic blistering in glass fibre hulls
- Solvent-free

ProPrimer 17600

Two-component epoxy propeller primer

Materials
Bronze / Stainless Steel
/ Anodized Aluminium /
Steel / **Aluminium**



Description

High performance epoxy primer for all propeller types, including bronze, stainless steel and aluminium, as well as external running gear.

Recommended use

Is intended as a primer direct to suitably prepared propellers, stern gear and running gear.

Product overview

Finish	Flat
Volume Solids (% - ±2)	68
Theoretical Spreading Rate	6.8 m ² /L – 150 µm WFT
Min. Overcoating Time (self)	10°C - 25 h 20°C - 16 h 30°C - 8 h
Min. Overcoating Time (other)	10°C - 4 h 20°C - 2.5 h 30°C - 2 h
Mixed VOC (g/L)	337

Shades & Can sizes



Application details

Mixing ratio	Base 17609 + Curing agent 97371 7.33 : 1 by volume
Thinner	08450
Cleaning of tools	Tool Cleaner 99610 Thinner 08450
Pot life (Airless spray)	10°C - 4 h 20°C - 3 h 30°C - 1 h
Film thickness (micron)	100 (dft) / 150 (wft)

- Excellent adhesion to propellers & running gear
- Ideal substrate for silicone systems
- Impact resistant

Thinners & Cleaners

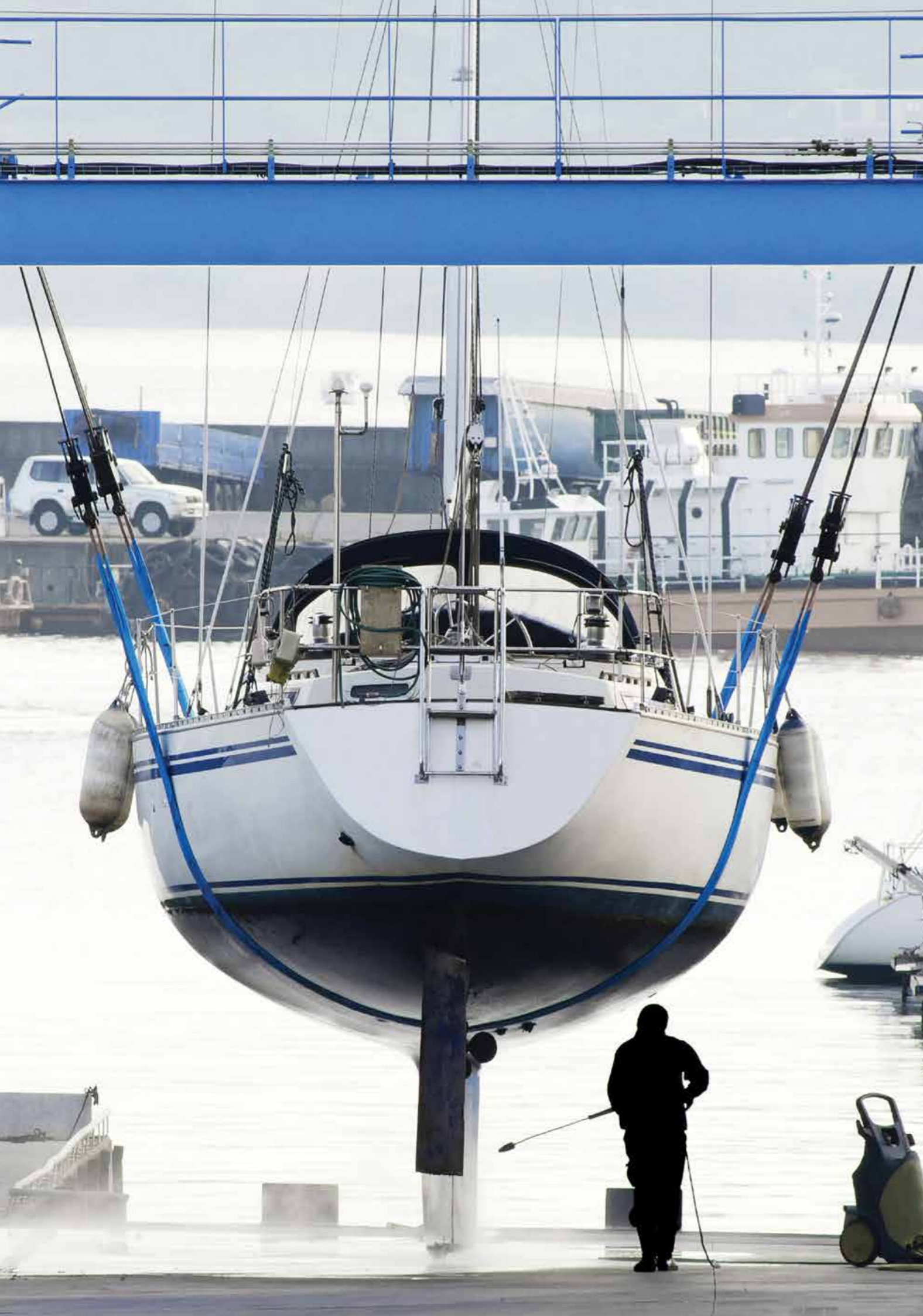

Thinners

Product name & Quality	Uses	Can size (L)
Hempel's Thinner 08080	For antifoulings, one-component primers, one-component topcoats, two-component topcoats	5 & 20
Hempel's Thinner 08111	For Underwater Primer 26031	5 & 20
Hempel's Thinner 08450	For two-component epoxy coatings	1 & 5 & 20
Hempel's Thinner 08710	For two-component polyurethane topcoats	5 & 20
Hempel's Thinner 08971	For interior coatings	5 & 25

Cleaners

Product name & Quality	Uses	Can size (L)
Hempel's Tool Cleaner 99610	For cleaning all tools	5 & 20
Hempel's Degreaser 99611	For removing grease and oils from metal surfaces	0.75
Hempel's Pre-Clean 67602	Universal surface pre-cleaner/surface re-activator	5

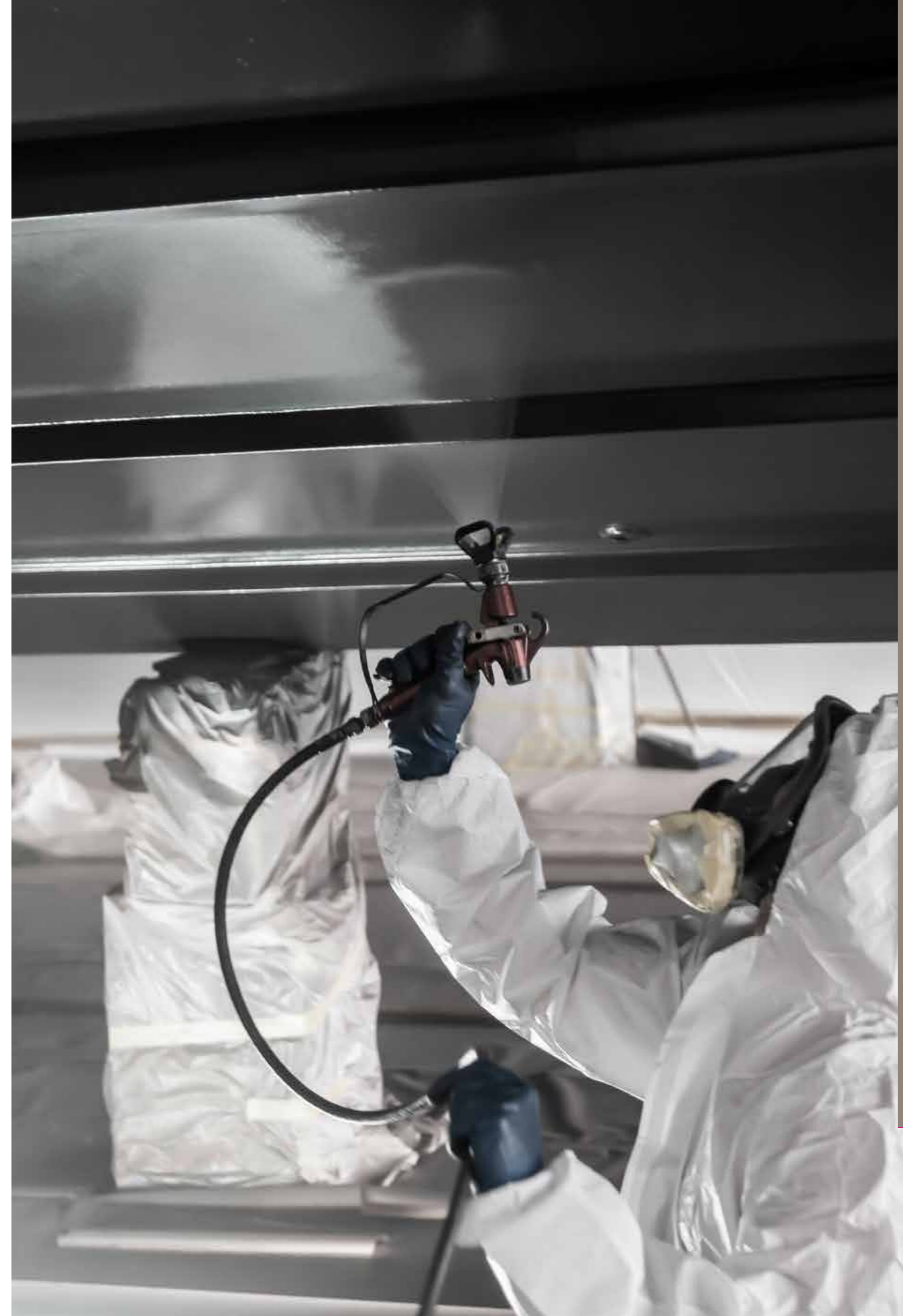

Health & Safety



Health & Safety

Your safety is important to us, this section is intended to make it easier for you to find the information you need to work safely with Hempel products. It is important that before starting work you:

- Ensure the area is safe to work in, with appropriate ventilation for the task ahead.
- Consider others working around you are also safe from exposure.
- Confirm that personal protective equipment (PPE) is used according to manufacturer's recommendations.
- Read the label, Safety Data Sheet (SDS) and other advice specific to the products you are working with.
- Read the Safe Use Mixture Information (SUMI) attached to SDS.
- Comply with local laws and regulations.

Hempel hopes that the Health and Safety section will increase awareness and inspire others to learn more about how to avoid risks to health and safety.

Safety Data Sheets

The main hazard and precautionary information is provided on labels alongside pictograms related to the hazard associated with the product. This should be your first reference in understanding how to handle the product safely. The Safety data sheet provides you with more detailed information. By using the information provided in the SDS and the label, you can make sure that it is safe to use the product where you work.

The Safety Data Sheet provides detailed information about a hazardous product, including: Its identity and its ingredients; Its physical, health and environmental hazards; Workplace exposure standards; Safe handling and storage procedures; First aid procedures; Transport information and other useful information. It is divided into 16 sections. Annexed to SDS is the Safe Use Mixture Information. One SUMI represents one specific application setup and provides detailed information like ventilation, duration of use and required PPE in a short easy readable one-pager.

Safety data sheets are available on hempel.com

Pictograms	Hazard class
	Explosive Self-reactive substances and mixtures Organic peroxides
	Flammable gases, aerosols, liquids or solids Self-reactive substances and mixtures. Pyrophoric liquids and solids. Self-heating substances. Substances, which in contact with water, emit flammable gases. Organic peroxides
	Oxidising substances
	Gas under pressure Compressed gasses. Liquefied gasses Refrigerated gasses. Dissolved gasses
	Corrosive Corrosive to metals Skin corrosion Severe eye damage
	Toxic (acute health hazard) Acute toxicity - via inhalation, skin contact or ingestion. These substances/mixtures can cause death, injury or seriously harm health within 72 hours of a single exposure
	Harmful Irritant to eyes and skin Skin sensitization Respiratory tract irritation Narcotic effects
	Chronic health hazard Products, which are Carcinogenic (can cause cancer), Mutagenic (can permanently change DNA), Reproductive toxic (can cause impaired fertility/birth defects), Respiratory sensitizers (can cause e.g. asthma)
	Hazardous to environment Environmental effects - both acute and chronic

Personal Protective Equipment

Personal Protective Equipment is used to protect workers in a specific work situation against health and safety risks where other controls can't provide total protection. PPE may also be required according to national legislation. Make sure that you check the manufacturer's recommendation to ensure that it is appropriate for the product you are working with. Damaged, dirty or used PPE may not be fully effective and you should maintain it according to recommendations from the supplier. If in any doubt, replace old equipment before starting work.

General good practice

Handling and Storage

Read the Product Data Sheet (PDS) and the Safety Data Sheet carefully as they contain information related to how to protect yourself and what to do in case of an accident. Access to both PDS and SDS shall be readily available on hempel.com

- Refer to safety/product data sheets for product information and content.
- Always read the label thoroughly and contact us if you're not sure how to use the products.
- Wear appropriate personal protective equipment (PPE).
- Provide adequate ventilation for the product used. If necessary, use a respirator. Don't breathe vapour/spray.
- Open cans with care.
- Immediately clean up spills.
- Do not eat or drink in the vicinity of stored or applied paint.
- Do not swallow. If swallowed, immediately seek medical advice and show the container/label.
- Some products may cause irritation, always seek medical advice if you're concerned.
- Where possible, removed waste antifouling paint, e.g. waste paint in cans and old paint scraped off of hulls, should be collected and disposed of safely.
- Contact your local authority for information on waste disposal.

Storage

- Do not store the paint in direct sunlight.
- A paint locker must be well ventilated and the light installed must be explosion proof. The locker must be in compliance with local legislation.
- When painting, protect the cans from dust and dirt.
- Keep the lids closed during storage.
- Secure all cans from falling down in bad weather.
- Do not leave thinners in open cans during storage.
- Using thinner will often lower the flash point and create a higher potential risk of explosion.
- Extra ventilation is required when using thinners as cleaning agent.
- Do not smoke or use open fire when handling paints.
- Spillages must be cleaned up immediately.
- All waste paint must be stored in special containers
- Personal protection such as gloves/goggles and often respirators must be used when handling paints.

Paint application

Brush & Roller

- The correct PPE shall be used during application and cleaning.
- Painting should be undertaken outdoors.
- During Indoor application adequate ventilation must be ensured, keep all windows and doors open where no mechanical ventilation/extraction is available.

Spray equipment









- Good maintenance - repairs before break down means improved safety.
- Only tested hoses, spray guns and fittings designed for maximum output pressure for each individual pump must be used.
- Always ground [earth] the pump to the subject to prevent explosion/fire due to sparks created by static electricity.
- Safety nozzle tips must be used on airless equipment.
- Do not point an airless gun at anybody.
- Be careful when using a powerful agitator/mixer to avoid paint/thinner splashing anybody.
- Full personal protection equipment is necessary when checking Wet Film Thickness (WFT) during spray application.

General good practice: around the work-site

- Keep the work-site clean and tidy.
- Smoking is allowed in designated areas only.
- Maintain safety and explosion proof lights.
- Ensure proper ventilation is maintained.
- Ensure that all work permits are available and valid.

Personal Protection

Ensure you wear suitable protective clothing, including gloves and glasses. Read labels carefully and follow all application and health & safety advice. Open cans with care. Don't eat or drink in the vicinity of stored or applied paint.

	What are the hazards	The equipment to use		What are the hazards	The equipment to use
 Eye	Chemical splash, dust, paint particles and droplets, projectiles, vapour.	Safety spectacles, goggles, face shields, visors.	 Hearing	Damage to inner ear from loud or constant noise levels.	Ear defenders, ear muffs, ear plugs.
 Breathing	Breathing dust, vapour, fumes, aerosols, oxygen-deficient atmospheres, paint particles.	Short term filtering mask against dust while sanding. Half facemask for sanding and painting, can be disposable or with replaceable filter cartridges. Full air feed facemask for spray painting.	 Body	Chemical or paint splash, spray from spray guns, impact or penetration, dust, excessive wear or entanglement of own clothing.	Overalls, coveralls.
 Hands	Abrasion, cuts and punctures, impact, chemicals, solvents, liquid paints, skin infection.	Leather gloves, latex gloves, armllets.	 Feet	Wet, slipping, cuts and punctures, falling objects, chemical and paint splash, abrasion.	Steel toe protection and anti-slip soles. May be a prerequisite on some sites.
 Hands	Dust, dirt, oil and grease, paint particles.	Barrier cream: short term protection. Cleaning cream: designed to remove contaminants and cause least skin damage. Maintenance cream: to help restore the skin's natural protective layers.	 Head	Impact from falling objects, head bumping, hair entanglement.	A range of helmets and bump caps.



Yacht Pro

Products for professional use
2026

As a world-leading supplier of trusted coating solutions, Hempel is a global company with strong values, working with customers in the protective, marine, decorative, container and yacht industries. Hempel factories, R&D centres and stock points are established in every region.

Across the globe, Hempel's coatings protect surfaces, structures and equipment. They extend asset lifetimes, reduce maintenance costs and make homes and workplaces safer and more colourful. Hempel was founded in Copenhagen, Denmark in 1915. It is proudly owned by the Hempel Foundation, which ensures a solid economic base for the Hempel Group and supports cultural, social, humanitarian and scientific purposes around the world.

Hempel UK Ltd.

Berwyn House
The Pavillions
Llantarnam Park, Cwmbran
South Wales NP443FD
hempel.com